

SPARE PARTS

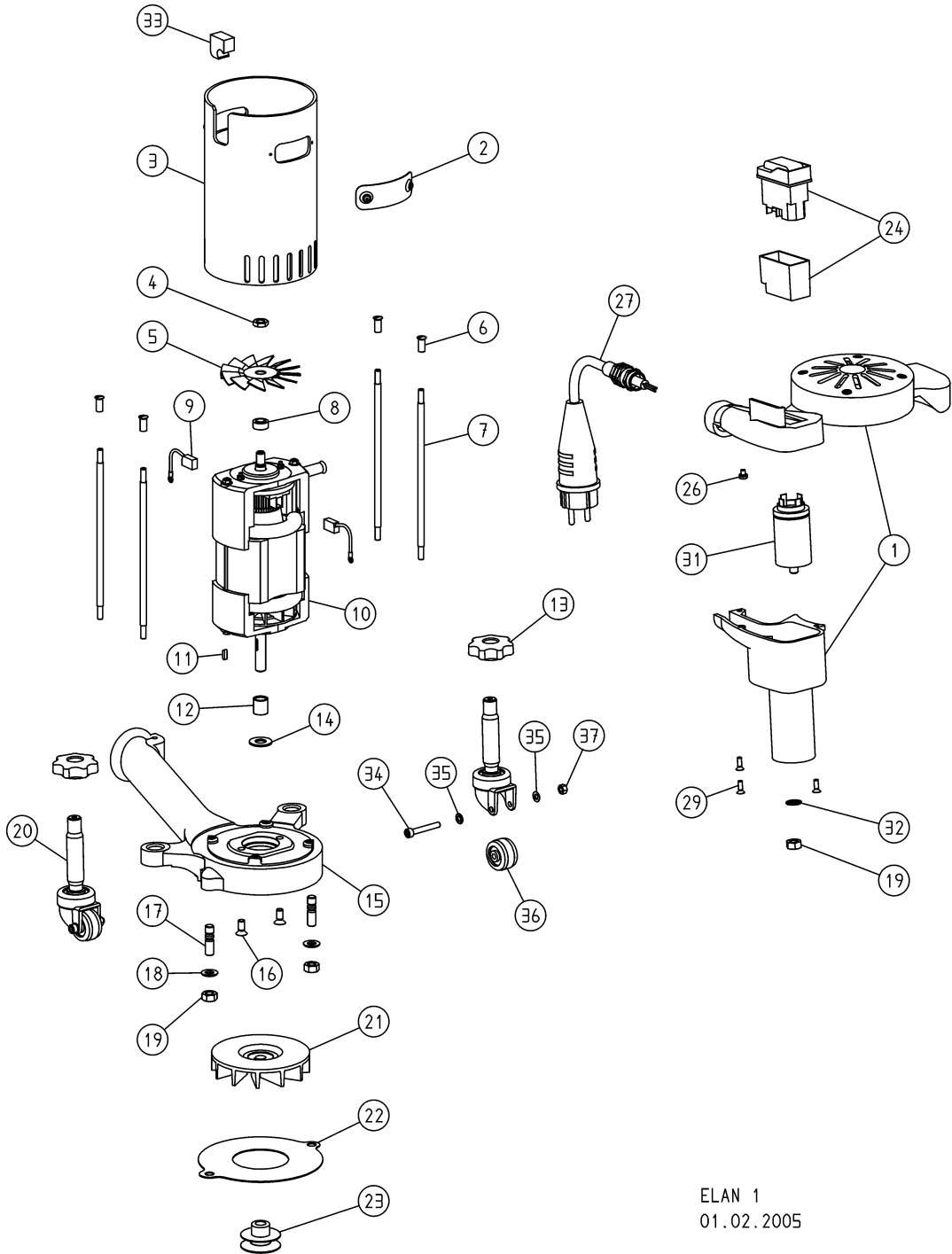

24

ELAN 1
01.02.2005

S P A R E P A R T S

Pos.	Product-No.	Description
1	350.05.00.100	Handle complete
	352.05.00.100	Handle complete, USA
2	350.05.15.100	Cover complete
3	350.05.10.100	Casing tube complete
4	0439.1008.800	Nut, left-handed thread
5	350.65.02.100	Fan blade
6	000.50.14.051	Sleeve nut
7	350.01.03.105	Spacer bolt
8	350.65.04.105	Spacer ring
9	350.65.82.105	Carbon brush ELAN
10	350.65.00.200	Universal motor, 230 V / 50 + 60 CPS
	352.65.00.200	Universal motor, 110 V / 50 + 60 CPS
11	6885.0303.010	Key
12	350.65.06.105	Spacer bush
13	320.05.11.205	Star grip (lock nut)
14	000.10.10.104	Washer
15	350.01.01.100	Fan housing
16	0965.1006.814	Screw
17	0939.1008.020	Stud
18	0125.1008.000	Washer
19	0934.1008.000	Nut
20	320.05.00.200	Guide roller, complete
21	350.65.03.100	Fan wheel
22	350.01.02.100	Fan cover
23	350.65.05.100	Motor pulley
24	000.65.60.255	Switch 230 V / 50 + 60 CPS with dust cover
	000.65.60.155	Switch 110 V / 50 + 60 CPS with dust cover
26	7985.4004.006	Screw
27	000.65.43.151	Motor cable 3 x 1.5 mm ²
	000.65.43.153	Motor cable 3 x 1.5 mm ² , USA
29	7500.1004.812	Screw
31	000.65.18.010	Interference-free capacitor
32	6797.1008.900	Washer
33	350.05.31.100	Sealing rubber
34	0912.1005.035	Screw
35	0125.1005.000	Washer
36	320.05.09.305	Wheel
37	0980.1005.000	Nut

SPARE PARTS

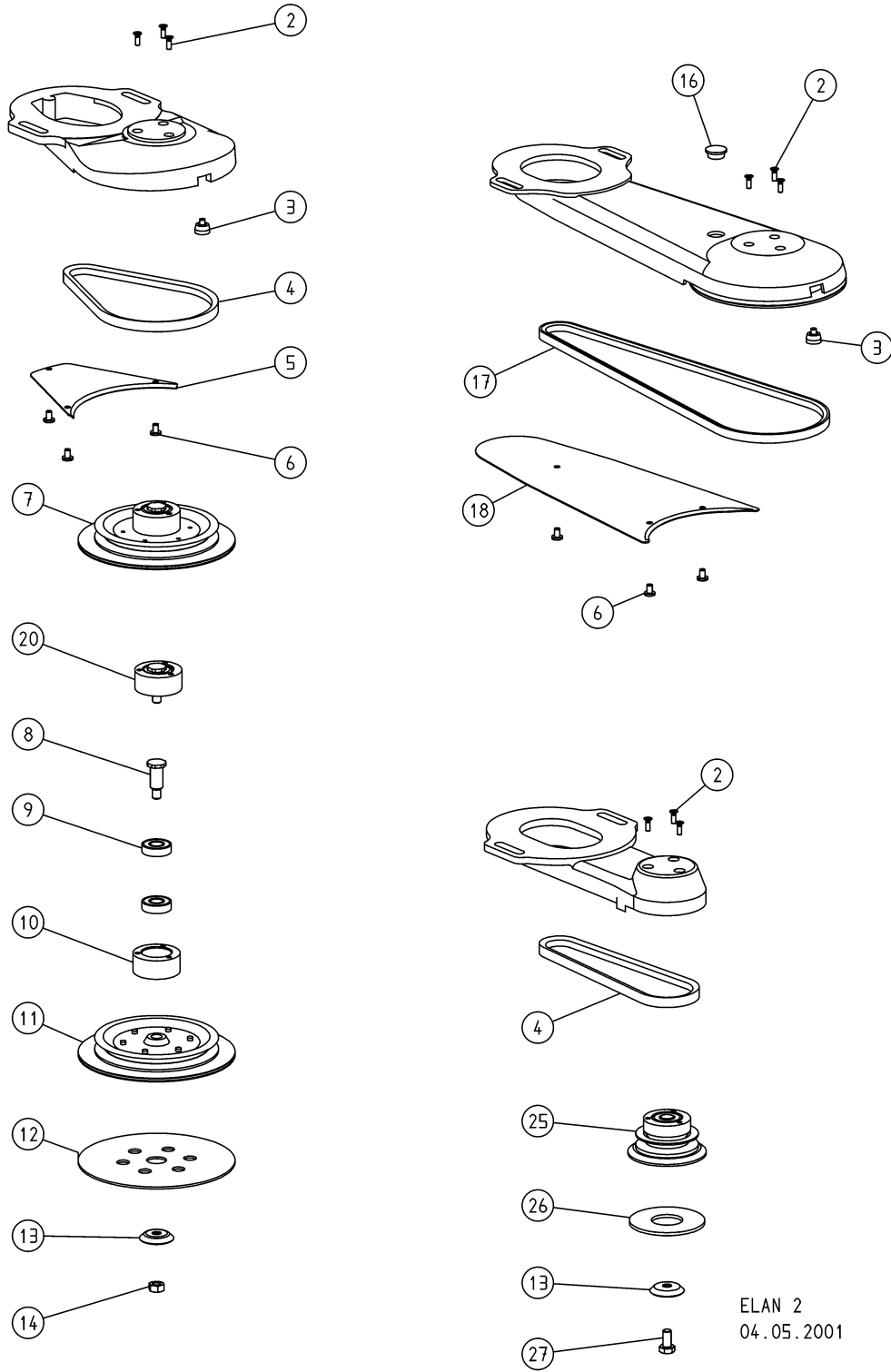

26

ELAN 2
04.05.2001

S P A R E P A R T S

Pos.	Product-No.	Description
	350.03.50.100	Short attachment ELAN, complete
2	7500.1004.812	Screw
3	350.03.25.100	Wall protecting roller, complete
4	000.71.24.044	V-belt 10 x 440
5	350.03.02.100	Cover, short
6	000.10.12.051	Screw
7	350.03.52.100	Steel sanding disc, complete
8	350.03.12.105	Sanding disc axle
9	6001.0012.202	Ball bearing
10	350.03.11.100	Bearing ring
11	350.03.56.100	V-belt pulley, complete
12	350.03.35.205	Velcro disc 150 mm
	350.03.34.105	Felt disc 150 mm
13	350.03.16.100	Paper tensioning disc
14	0934.1008.000	Nut
	350.04.50.100	Long attachment ELAN, complete
16	000.40.30.017	Plug
17	000.71.51.084	V-belt 10 x 840
18	350.04.02.100	Cover, long
20	350.03.48.100	Bearing ring, complete
	350.08.00.100	Corner attachment ELAN, complete
25	350.08.10.100	Steel sanding disc 75 mm, complete
26	350.08.13.105	Felt disc 75 mm
27	0933.1008.016	Screw

SPARE PARTS

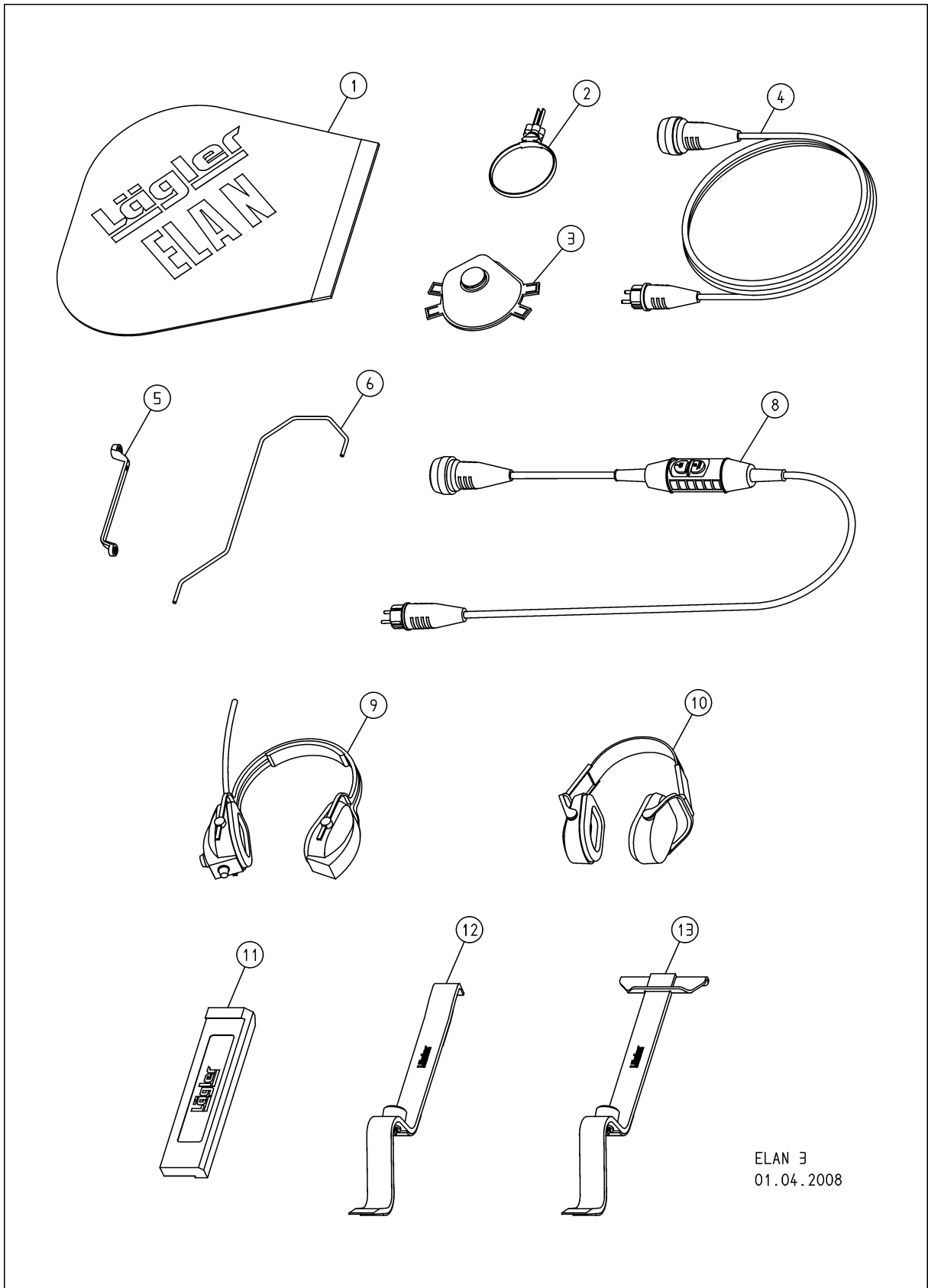

ELAN 3
01.04.2008

S P A R E P A R T S

Pos.	Product-No.	Description
1	350.00.80.105	Dust bag ELAN
2	000.01.40.110	Multiclip
3	000.01.20.010	Protective mask P3
4	000.65.53.151	Extension cable 3 x 1.5 mm ² , 10 m long
5	000.95.21.103	Closed mouth wrench
6	350.01.05.200	Dust bag clamp
8	000.01.65.020	Protective switch for fault current
9	000.01.10.011	Foldable earmuff type MUSIMUFF with FM radio
10	000.01.10.021	Foldable earmuff type POCKET
11	701.10.00.100	Impact tool
12	702.00.00.200	Parquet layer tool, small
13	703.00.00.200	Parquet layer tool, broad

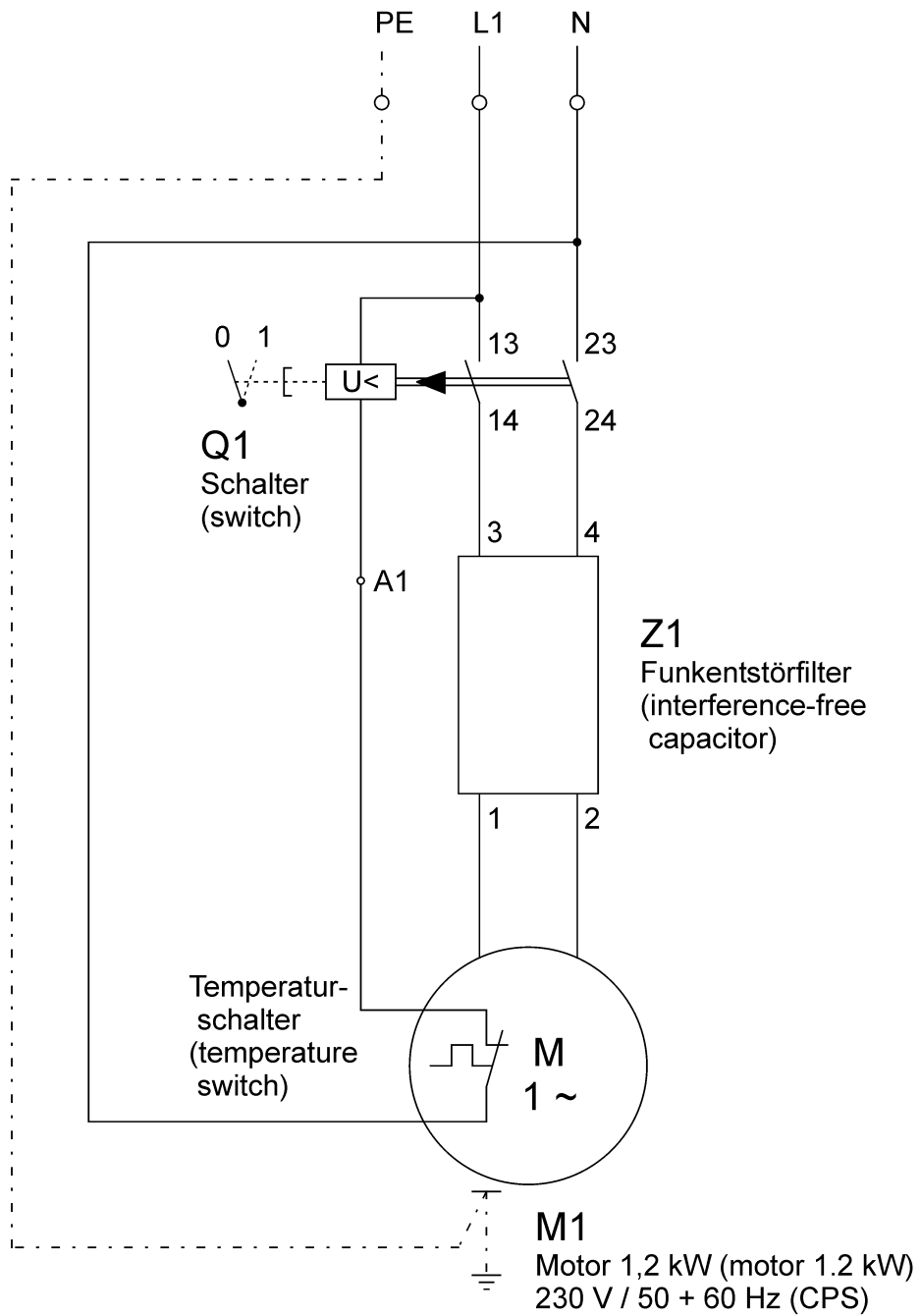

01.04.2008

ELAN: **Universalmotor**
(universal motor)

1,2 kW (1.2 kW) / 230 V / 50 + 60 Hz (CPS)

EUGEN LÄGLER GMBH
Industriegebiet Kappelrain
D-74363 Güglingen-Frauenzimmern

Telefon
Phone : +49 - 7135 - 98 90 - 0
Fax: +49 - 7135 - 98 90 - 98

E-Mail: info@laegler.com
Internet: <http://www.laegler.com>

CIRCUIT DIAGRAM

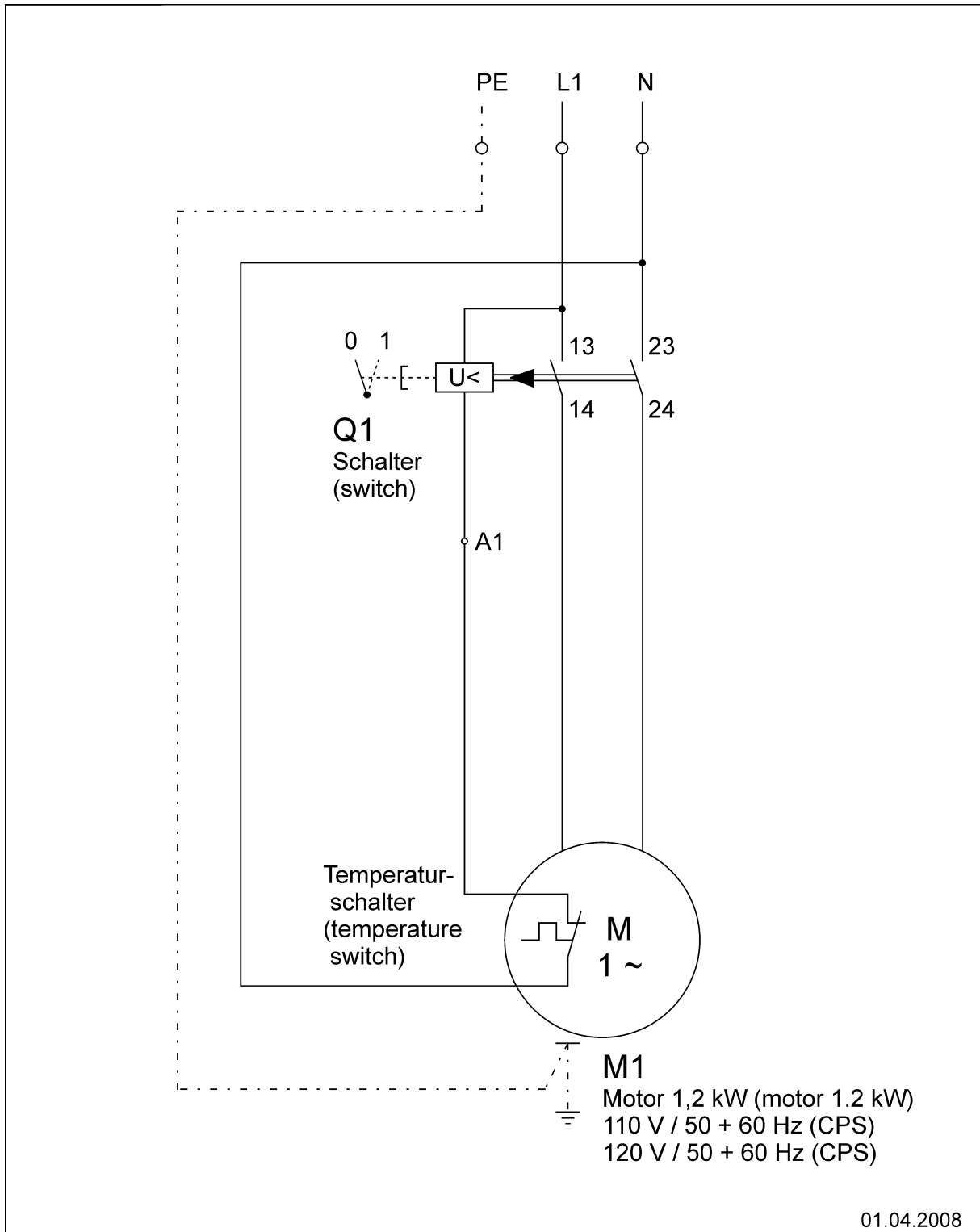

ELAN: Universalmotor (universal motor)	1,2 kW (1.2 kW) / 110 V / 50 + 60 Hz (CPS)
	1,2 kW (1.2 kW) / 120 V / 50 + 60 Hz (CPS)

EUGEN LÄGLER GMBH Industriegebiet Kappelrain D-74363 Güglingen-Frauenzimmern	Telefon Phone : +49 - 7135 - 98 90 - 0 Fax: +49 - 7135 - 98 90 - 98	E-Mail: info@laegler.com Internet: http://www.laegler.com
--	---	--

N O T E S